

EL CAMINO

André Mittwollen
Gartenstraße 33
26122 Oldenburg
adynaton@gmx.de
+49 178 681 59 56

from Lönigen, Lower Saxony, Germany

Style

Heavy Rock, Stoner, and Metal! With their earthy riffs, powerful grooves, and meaty-raw vocals, El Camino will grab you by the neck and never let go!

Crew

Jan (Guitar)

Martin (Vocals)

André (Drums)

Dennis (Bass)

News

El Camino are working on new songs for their next album – brace yourself for a mighty share of Doom and Stoner! Their Single “Rider” contains two new tracks and has just been published on SoundCloud and Bandcamp. Concerts for 2020 have also been booked - scroll their websites for gigs, come around and get rocked!

Websites & Samples

<http://elcaminorocks.de>

<http://facebook.com/elcaminorocks>

<http://elcaminorocks.bandcamp.com>

<https://soundcloud.com/elcaminorocks>

EL CAMINO

André Mittwollen
Gartenstraße 33
26122 Oldenburg
adynaton@gmx.de
+49 178 681 59 56

from Lönigen, Lower Saxony, Germany

Band Biography

Dennis, Jan and Werner form El Camino in the beginning of 2006 to live out their passion for Heavy Rock with Stoner influences. The side project turns into an ambitious band...



2008 – Hit The Road

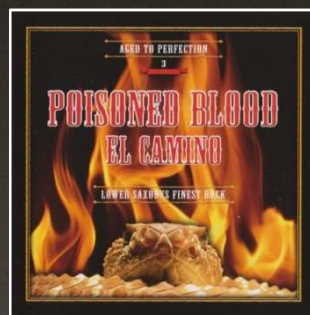

2010 – Poisoned Blood



2014 – Black Fuel

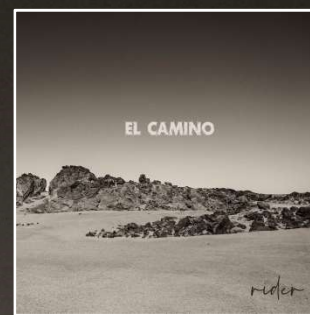

2019 – Rider (Promo)

...that, after two line-up changes, publishes its debut *Hit The Road* in November 2008 and earns some critical acclaim: "If this doesn't make you groove, it's your own fault." (heavyhardes.de)

Their sophomore album *Poisoned Blood* is launched in 2010 and gets some good reviews as well: "Fact is that this quintet with their meaty, mighty riffs, put into practise uncompromisingly and relentlessly, should be of highest interest for all fans of honest rock music." (metal.de)

Their third album *Black Fuel* features even more melodies and forceful riffing. It is released on the 10th of May, 2014 and "rocks massively." (powermetal.de)

With their current Promo-Single "Rider", El Camino give a glimpse at their next album: a thick portion of Stoner and Doom makes the new songs more colorful, rougher and catchier.

EL CAMINO

André Mittwollen
Gartenstraße 33
26122 Oldenburg
adynaton@gmx.de
+49 178 681 59 56

from Lönigen, Lower Saxony, Germany

Stage experience

During their twelve-year orbit around Lower Saxony and North-Rhine Westfalia, El Camino have played on over 120 stages. Renowned clubs such as MTS Records in Oldenburg, the Bastard Club in Osnabrück and Rare Guitar in Münster call them on a regular basis. Be it as a support for international underground acts, i. e. The Re-Stoned, Sasquatch and Gozu, or be it as co-hosts for concerts with friends like Mount Atlas, Bushfire and VUG – El Camino always deliver!



El Camino have thrilled their audience – among others – at the:

- Metal-Mixer, JuZ Cadillac, Oldenburg, October 2006;
- Kottenrock-Indoor with Volt and Rotor, Gulfhaus, Vechta, December 2007;
- AStA-Festival, Glanz and Gloria, Osnabrück, May 2008;
- Hasetal Open-Air with Pressure Recall and Alienated, Lönigen, July 2009;
- Prison Break-Konzert, JVA Vechta, February 2010;
- Too stoned! with Eta Lux, Römer, Bremen, September 2011;
- X-Mas-Special with Mr. Irish Bastard, Rosenhof, Osnabrück, December 2012;
- City-Fest Cloppenburg with The Mortis, Bebop, September 2013;
- Brave Black Sea, Bastard Club, Osnabrück, June 2014;
- Rock im Moor, JuZ Papenburg, June 2015;
- Düte Rockt-Festival, Osnabrück, July August 2015;
- Hütte Rockt-Festival, Osnabrück, August 2015;
- Bushfire, Rare Guitar, Münster, September 2015;
- Lizardmen and The Coffin Riders, MTS Records, Oldenburg, October 2016;
- Lords Of Darkness, Rare Guitar, Münster, December 2017;
- Let the Bad Times Roll-Festival, Manslagt, Juni 2018;
- Gozu-Konzert, MTS in Oldenburg, November 2019.

EL CAMINO

André Mittwollen
Gartenstraße 33
26122 Oldenburg
adynaton@gmx.de
+49 178 681 59 56

from Lönigen, Lower Saxony, Germany



2007



2010



2017

EL CAMINO

Stage plan

André Mittwollen
Gartenstraße 33
26122 Oldenburg
adynaton@gmx.de
+49 178 691 59 56

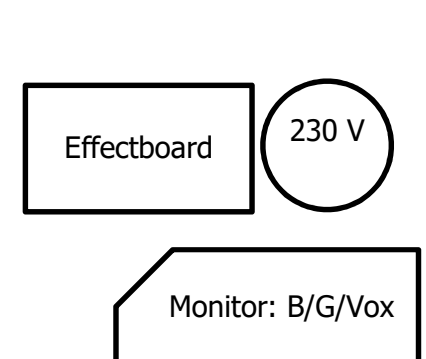
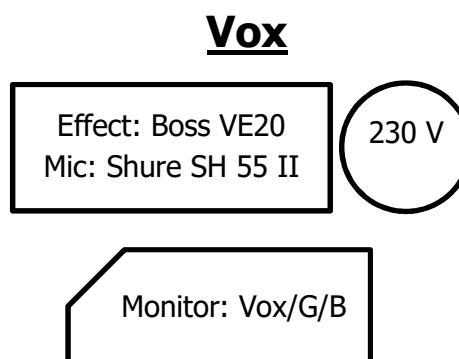
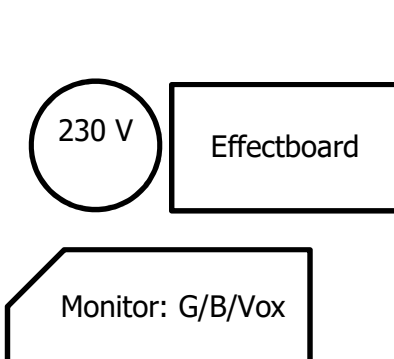
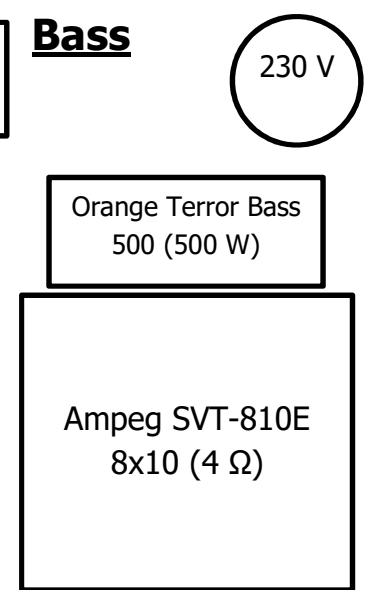
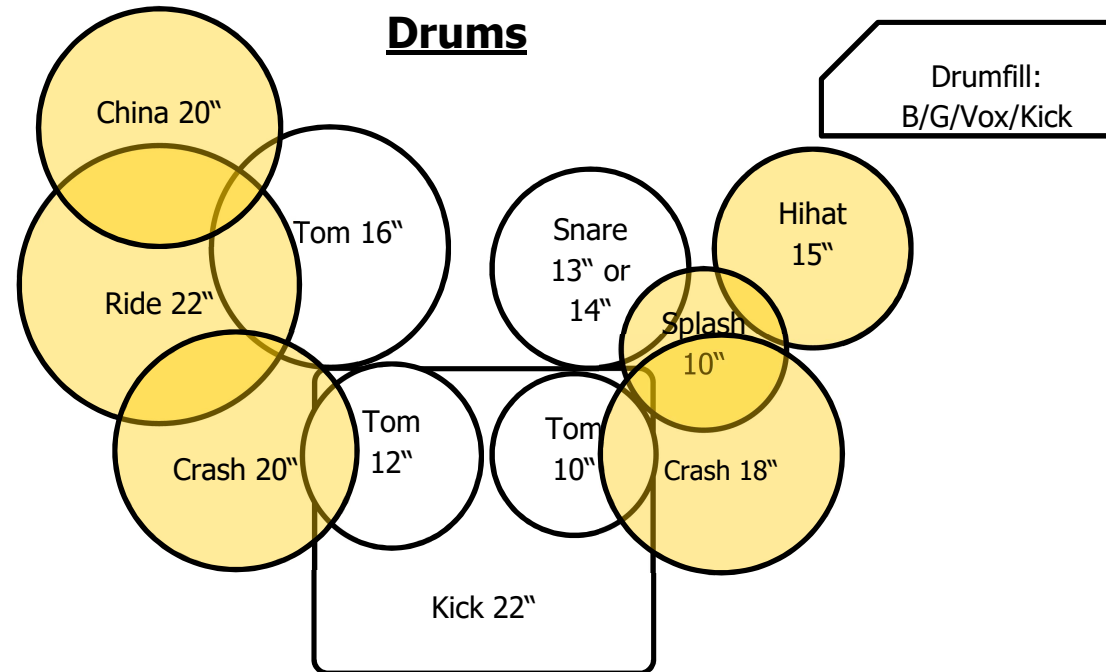
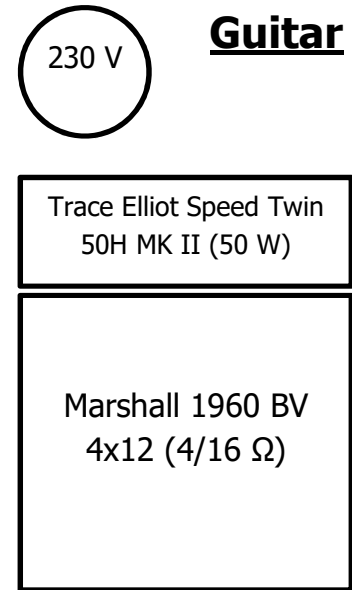

This technical rider is part of the guest performance contract.

The band consists of four musicians (dr/b/g/vox). Maybe, of course according to prior written agreement with the organizer, the band will be accompanied by a merch assistant. The band will not bring any technical personnel, i. e. the organizer must provide a sound and, if required, a lighting technician.

The short list in pp. 1 & 2 serves as a quick orientation. Details of the technical requirements as well as the terms of providing and sharing for the backline and the PA system are noted in pp. 3 & 4.

Backline requirements

- Shell set: one kick drum, two rack toms and one floor tom (if need be, one rack tom and one floor tom will suffice).
- Guitar cab: 4x12" (4 or 16 Ω, Marshall preferred).
- Bass cab: 4x10" at least (4 or 8 Ω).
- Vox: There is only one lead singer in the band. He has no preferences concerning microphones; in case he's forgotten his Shure SH55 II, the "usual suspects" (see p. 2, input list) are fully sufficient.
- Microphoning: At smaller indoor venues (up to 100 visitors), the kick and – if required – the toms should be mic'ed (in addition to the guitar cab and the bass cab).
- PA: No preferences, as long as it is appropriate for the location/audience and strong enough for high volumes with a punchy, clipping-free sound.

Monitoring

On a small stage where the musicians can hear each other, the wedges only have to display the guitar, the bass and the vocals. On bigger stages, kick, snare and hihat should be put on the wedges as well. The drum fill should display the guitar, the bass, the vocals as well as the kick drum.

Miscellaneous

Five connections for power supply are required. Changeovers are usually done without stage hands in 15 minutes. If a sound check is impossible, a line check directly before the gig will do.

Sound

Guitar and bass are – depending on the song – tuned to C# or Drop H. Their sound should fit the genre stoner rock; in this respect, the amps are already well-adjusted. If possible, a natural drum sound with a moderate "click" in the kick drum sound and as little gate as possible on the toms is preferred. Light reverb on the vocals would be optimal.

Mixing console/Input list

- 12 Microphone channels: kick, snare, hihat, 3 x tom, 2 x overhead, guitar, bass, vox
- (with the band's own PA system: kick, snare, 2 x overhead, guitar, bass, vox)

Channel	Input	Mic	Insert
1	kick drum	e. g. beta52 or e602	gate
2	snare batter	e. g. sm57	comp
3	hihat	condensator (e. g. C451)	
4	tom 1	e. g. beta98 or e904	gate (light)
5	tom 2	e. g. beta98 or e904	gate (light)
6	tom 3	e. g. beta98 or e904	gate (light)
7	overhead right	condensator (e. g. NT5)	
8	overhead left	condensator (e. g. NT5)	
9	guitar	e. g. e906 or sm57	
10	bass	DI	comp
11	bass amp (opt.)	e. g. Re20 or e602	comp
12	vox	e. g. SM58, e935 etc.	comp, light reverb

Light

The band has no definite light show and would even be content with two living room lamps set up in each back corner of the stage. However, some varied stage lighting would be greatly appreciated.

Merchandise

A table (ca. 60 cm x 100 cm) and a chair will do.

Catering

The band consists of easy-to-please omnivores. Vegetarian and vegan meals will be accepted, but standard meals are preferred. As for drinks (beside the usual "band crate" of beer), one litre of mineral water (medium or still) should be provided for each band member.

Sleepover

Should a sleepover be necessary, four mattresses and four pillows in a dark, dry, warm room within walking distance to the venue will do. The band will bring bedclothes/sleeping bags.

Pay

Up to a distance of 100 km from the band's rehearsal place, the regular fee is 150 €. With greater distances, the fee increases by 1,50 €/km. Agreements differing from this regulation must be negotiated and noted in the guest performance contract.

We're looking forward to working with you, here's to a successful gig!

Personal equipment ("always on board")

As listed above, each band member will bring their own standard equipment, some of which may be shared with other musicians (according to prior written agreement).

- The drummer will, in addition to cymbals, sticks and other personal gear, definitely bring the following equipment:
 - a 13"x6,5" snare drum with "Air Ride" stand or a 14"x08" with a "Low" snare stand, a double foot pedal (right), a two-legged hi-hat stand, a stable drum throne with spindle, and three cymbal stands plus two cymbal arms (incl. multi-clamps) with functional washers, felts, cymbal mates and nylon sleeves.
 - Other drummers may use everything but the "Air Ride", cymbals, sticks and the 14"x08" snare.
- The guitar player will, in addition to his instrument, effect board, picks and other personal gear, definitely bring a 50-Watts valve amp. The amp may be used by other guitarists.
- The bass player will, in addition to his instrument, effect board, picks and other personal gear, definitely bring a 500-Watts digital amp. The amp may be used by other bassists.
- The singer will definitely bring his own Shure SH55 II.

PA system

The following PA system has been used for several self-organized concerts in a venue with an area of approx. 400 m²/for about 150 visitors. It provides a loud, punchy and clipping-free sound.

- Peavey PR15 speakers (2012):
 - Two-way-speakers: 15"-woofer with 2-3/8"-tweeter, 400 W
 - Input: 2 x 6,3 mm plug
 - Dimensions: 550 mm x 730 mm x 431 mm / Weight: ca. 6 kg
- Speaker stands (resembling the Millennium BS 2211 b Mk II):
 - up to 30 kg central load
 - height 1,25 m up to ca. 2,00 m
 - Pole diameter: 35 mm
- the box CL 115 (2014):
 - Power: 220 W RMS / 500 W Peak + 2 x 220 / 500 W RMS / Peak for the Top thomann speakers
 - Peak SPL: 122 dB
 - Internal crossover
 - Frequency range: 35 - 130 Hz
 - Input: 2 x XLR, 2 x 1/4" jack / Outputs: 2 x Speaker Twist
 - Pole mount: 36 mm
 - Dimensions: 460 mm x 565 mm x 610 mm / Weight: 40 kg
- the t.mix pm 800 Powermixer (2008):
 - Power: 250 W, 4 Ohm
 - Input: 8 x mono, 1 x stereo / Output: Speaker Twist
 - 24-Bit multi-effects processor with 99 Presets
 - Clip-LED per channel
 - 7-Band Thomann stereo master-EQ, Master compressor/Limiter
 - 12 V lamp connector
 - Dimensions: 530 mm x 260 mm x 260 mm / Weight: 11,7 kg